

D-M-E 2-Stage Ejector Bottom Last (TS BL) Sequencing

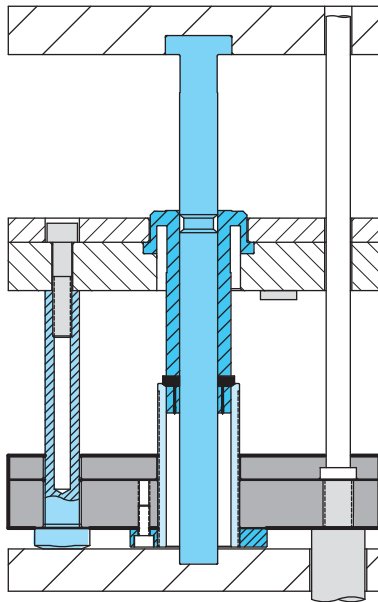

1. Ejector Plates Back

Patent No. 6.575.730
Patent No. 6.106.271
(Additional patents pending)

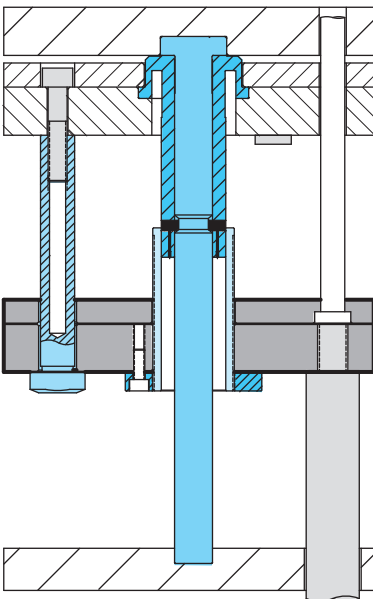

2. First Ejector Stroke

After a predetermined amount of travel, the latch mechanism latches onto the Center Rod, thereby fixing the position of the top (stationary platen side) ejector plate assembly.

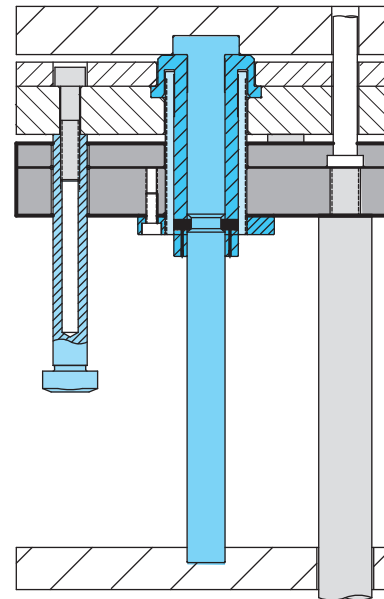

3. Second Ejector Stroke

The bottom (moving platen side) ejector plate assembly continues to move through the "second" (or remaining) stroke until the bottom ejector plate assembly contacts the top ejector plate assembly.